



# Operating Instructions and Parts Manual 14-inch Woodworking Band Saw

Model: JWBS-140S



**JET**  
427 New Sanford Road  
LaVergne, Tennessee 37086  
Ph.: 800-274-6848  
[www.jettools.com](http://www.jettools.com)

**Part No. M-708113A**  
Revision C2 02/2014  
Copyright © 2014 JET

# Warranty and Service

JET warrants every product it sells against manufacturers' defects. If one of our tools needs service or repair, please contact Technical Service by calling 1-800-274-6846, 8AM to 5PM CST, Monday through Friday.

## Warranty Period

The general warranty lasts for the time period specified in the literature included with your product or on the official JET branded website.

- JET products carry a limited warranty which varies in duration based upon the product. (See chart below)
- Accessories carry a limited warranty of one year from the date of receipt.
- Consumable items are defined as expendable parts or accessories expected to become inoperable within a reasonable amount of use and are covered by a 90 day limited warranty against manufacturer's defects.

## Who is Covered

This warranty covers only the initial purchaser of the product from the date of delivery.

## What is Covered

This warranty covers any defects in workmanship or materials subject to the limitations stated below. This warranty does not cover failures due directly or indirectly to misuse, abuse, negligence or accidents, normal wear-and-tear, improper repair, alterations or lack of maintenance.

## Warranty Limitations

Woodworking products with a Five Year Warranty that are used for commercial or industrial purposes default to a Two Year Warranty. Please contact Technical Service at 1-800-274-6846 for further clarification.

## How to Get Technical Support

Please contact Technical Service by calling 1-800-274-6846. **Please note that you will be asked to provide proof of initial purchase when calling.** If a product requires further inspection, the Technical Service representative will explain and assist with any additional action needed. JET has Authorized Service Centers located throughout the United States. For the name of an Authorized Service Center in your area call 1-800-274-6846 or use the Service Center Locator on the JET website.

## More Information

JET is constantly adding new products. For complete, up-to-date product information, check with your local distributor or visit the JET website.

## How State Law Applies

This warranty gives you specific legal rights, subject to applicable state law.

## Limitations on This Warranty

JET LIMITS ALL IMPLIED WARRANTIES TO THE PERIOD OF THE LIMITED WARRANTY FOR EACH PRODUCT. EXCEPT AS STATED HEREIN, ANY IMPLIED WARRANTIES OF MERCHANTABILITY AND FITNESS FOR A PARTICULAR PURPOSE ARE EXCLUDED. SOME STATES DO NOT ALLOW LIMITATIONS ON HOW LONG AN IMPLIED WARRANTY LASTS, SO THE ABOVE LIMITATION MAY NOT APPLY TO YOU.

JET SHALL IN NO EVENT BE LIABLE FOR DEATH, INJURIES TO PERSONS OR PROPERTY, OR FOR INCIDENTAL, CONTINGENT, SPECIAL, OR CONSEQUENTIAL DAMAGES ARISING FROM THE USE OF OUR PRODUCTS. SOME STATES DO NOT ALLOW THE EXCLUSION OR LIMITATION OF INCIDENTAL OR CONSEQUENTIAL DAMAGES, SO THE ABOVE LIMITATION OR EXCLUSION MAY NOT APPLY TO YOU.

JET sells through distributors only. The specifications listed in JET printed materials and on official JET website are given as general information and are not binding. JET reserves the right to effect at any time, without prior notice, those alterations to parts, fittings, and accessory equipment which they may deem necessary for any reason whatsoever. JET® branded products are not sold in Canada by JPW Industries, Inc.

## Product Listing with Warranty Period

90 Days – Parts; Consumable items; Light-Duty Air Tools
1 Year – Motors; Machine Accessories; Heavy-Duty Air Tools; Pro-Duty Air Tools
2 Year – Metalworking Machinery; Electric Hoists, Electric Hoist Accessories; Woodworking Machinery used for industrial or commercial purposes
5 Year – Woodworking Machinery
Limited Lifetime – JET Parallel clamps; VOLT Series Electric Hoists; Manual Hoists; Manual Hoist Accessories; Shop Tools; Warehouse & Dock products; Hand Tools

NOTE: JET is a division of JPW Industries, Inc. References in this document to JET also apply to JPW Industries, Inc., or any of its successors in interest to the JET brand.

# Table of Contents

Warranty and Service .....	2
Table of Contents .....	3
Warnings .....	4
Specifications .....	6
Shipping Contents .....	7
Contents of the Carton .....	7
Hardware Bag for Saw Body .....	7
Hardware Bag for Stand Assembly .....	8
Tools Required for Assembly .....	8
Assembly .....	8
Unpacking and Cleanup .....	8
Stand .....	8
Mounting Bandsaw to Table .....	9
Mounting the Motor .....	9
Mounting the Switch .....	10
Cord Clamp .....	10
Upper Blade Guard Assembly .....	11
Table Assembly .....	11
Grounding Instructions .....	12
115 Volt Operation .....	12
230 Volt Conversion .....	12
Extension Cords .....	13
Adjustments .....	14
Tilting the Table .....	14
Adjusting 90° Table Stop .....	14
Changing Blades .....	14
Adjusting Blade Tension .....	15
Adjusting Blade Tracking .....	15
Adjusting Upper Blade Guide Assembly .....	16
Blade Guide Adjustment .....	16
Blade Support Bearing Adjustment .....	16
Optional Accessories .....	17
Troubleshooting JWBS-14OS Band Saw .....	18
Replacement Parts .....	18
Body Assembly (JWBS-14OS Band Saw) .....	19
Open Stand Assembly (JWBS-14OS Band Saw) .....	23
Electrical Connections .....	24

The specifications in this manual are given as general information and are not binding. JET reserves the right to effect, at any time and without prior notice, changes or alterations to parts, fittings, and accessory equipment deemed necessary for any reason whatsoever.

# Warnings

1. Read and understand the entire owner's manual before attempting assembly or operation.
2. Read and understand the warnings posted on the machine and in this manual. Failure to comply with all of these warnings may cause serious injury.
3. Replace the warning labels if they become obscured or removed.
4. This band saw is designed and intended for use by properly trained and experienced personnel only. If you are not familiar with the proper and safe operation of a band saw, do not use until proper training and knowledge have been obtained.
5. Do not use this band saw for other than its intended use. If used for other purposes, JET disclaims any real or implied warranty and holds itself harmless from any injury that may result from that use.
6. Always wear approved safety glasses/face shields while using this band saw. Everyday eyeglasses only have impact resistant lenses; they are not safety glasses.
7. Before operating this band saw, remove tie, rings, watches and other jewelry, and roll sleeves up past the elbows. Remove all loose clothing and confine long hair. Non-slip footwear or anti-skid floor strips are recommended. Do **not** wear gloves.
8. Always use the blade guard on all "through-sawing" operations. A through-sawing operation is one in which the blade cuts completely through the workpiece.
9. Some dust created by power sanding, sawing, grinding, drilling and other construction activities contain chemicals known to cause cancer, birth defects or other reproductive harm. Some examples of these chemicals are:
  - Lead from lead based paint.
  - Crystalline silica from bricks, cement and other masonry products.
  - Arsenic and chromium from chemically treated lumber.Your risk of exposure varies, depending on how often you do this type of work. To reduce your exposure to these chemicals, work in a well-ventilated area and work with approved safety equipment, such as face or dust masks that are specifically designed to filter out microscopic particles.
10. Do not operate this machine while tired or under the influence of drugs, alcohol or any medication.
11. Make certain the switch is in the **OFF** position before connecting the machine to the power supply.
12. Make certain the machine is properly grounded.
13. Make all machine adjustments or maintenance with the machine unplugged from the power source.
14. Remove adjusting keys and wrenches. Form a habit of checking to see that keys and adjusting wrenches are removed from the machine before turning it on.
15. Keep safety guards in place at all times when the machine is in use. If removed for maintenance purposes, use extreme caution and replace the guards immediately.
16. Make sure the band saw is firmly secured to the stand (or bench) before use.
17. Check damaged parts. Before further use of the machine, a guard or other part that is damaged should be carefully checked to determine that it will operate properly and perform its intended function. Check for alignment of moving parts, binding of moving parts, breakage of parts, mounting and any other conditions that may affect its operation. A guard or other part that is damaged should be properly repaired or replaced.
18. Provide for adequate space surrounding work area and non-glare, overhead lighting.

# Warnings

19. Provide for adequate space surrounding work area and non-glare, overhead lighting.
20. Keep the floor around the machine clean and free of scrap material, oil and grease.
21. Keep visitors a safe distance from the work area. **Keep children away.**
22. Make your workshop child proof with padlocks, master switches or by removing starter keys.
23. Give your work undivided attention. Looking around, carrying on a conversation and “horse-play” are careless acts that can result in serious injury.
24. Maintain a balanced stance at all times so that you do not fall into the blade or other moving parts. Do not overreach or use excessive force to perform any machine operation.
25. Use the right tool at the correct speed and feed rate. Do not force a tool or attachment to do a job for which it was not designed. The right tool will do the job better and safer.
26. Use recommended accessories; improper accessories may be hazardous.
27. Maintain tools with care. Keep saw blades sharp and clean for the best and safest performance. Follow instructions for lubricating and changing accessories.
28. Make sure the work piece is held firmly against the rip fence or miter gauge as it is fed through the blade.
29. Turn off the machine before cleaning. Use a brush or compressed air to remove chips or debris — do not use your hands.
30. Do not stand on the machine. Serious injury could occur if the machine tips over.
31. Never leave the machine running unattended. Turn the power off and do not leave the machine until it comes to a complete stop.
32. Remove loose items and unnecessary work pieces from the area before starting the machine.

**Familiarize yourself with the following safety notices used in this manual:**

## CAUTION

This means that if precautions are not heeded, it may result in minor injury and/or possible machine damage.

## WARNING

This means that if precautions are not heeded, it may result in serious injury or possibly even death.

# Specifications

Model Number.....	JWBS-14OS
Stock Number.....	708113A
Cutting Capacity (height/in.).....	6
Cutting Capacity (width/in.).....	13-1/2
Minimum Blade Width (in.).....	1/8
Maximum Blade Width (in.).....	3/4
Blade Length (in.).....	93-1/2
Blade Speed (SFPM).....	3000
Table Size (in.).....	14x 14
Table Slot Size (DxW/in.).....	3/8 x 3/4
Table Height From Floor (in.).....	44
Table Tilt (deg.).....	45 right, 10 left
Dust Port Diameter (in.).....	4
Overall Dimensions (HxWxD/in.).....	68 x24x 26-1/2
Motor.....	TEFC, 3/4HP, 1Ph, 115/230V (prewired 115), 60Hz
Net Weight (lbs.).....	161
Shipping Weight (lbs.).....	172

**⚠WARNING** Read and understand the entire contents of this manual before attempting assembly or operation! Failure to comply may cause serious injury!

# Shipping Contents

## Contents of the Carton

- 1 – Body Assembly (1)
- 3 – Table (1)
- 4 – Trunnion Support Bracket (1)
- 5 – Motor (1)
- 6 – Switch Box (1)
- 10 – Upper Support Bracket Post (1)
- 11 – Lower Support Bracket Post (1)
- 12 – Upper Blade Guard (1)
- 13 – Lower Blade Guard (1)
- 14 – Lock Knobs (2)
- 15 – Owner's Manual (1)
- 16 – Hardware Bag for Saw Body (1)
- 17 – Hardware Bag for Stand (1)
- 18 – Base Plate (1)
- 19 – Stand Leg (4)
- 20 – Short Support Plate (2)
- 21 – Long Support Plate (2)
- 22 – Rubber Foot (4)

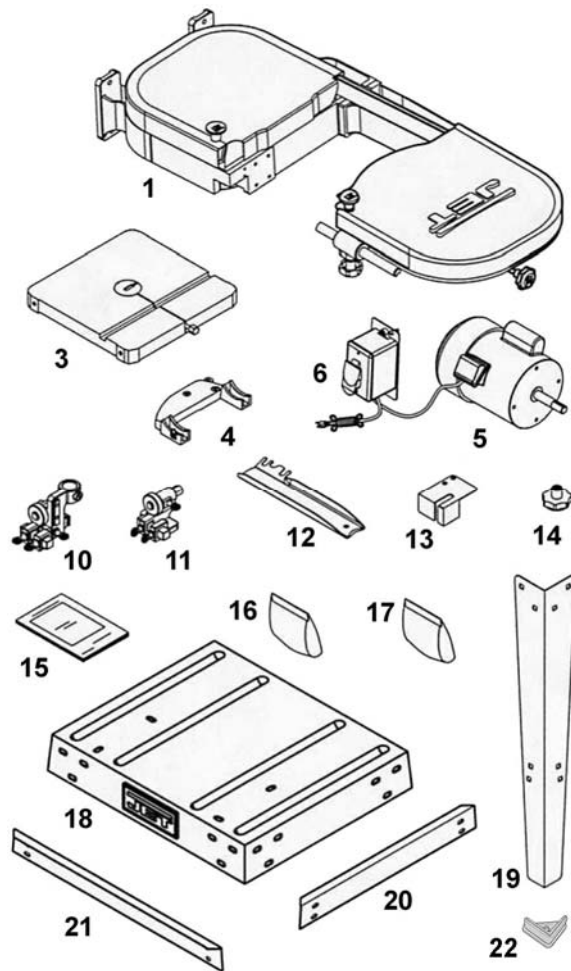

Contents of the Carton

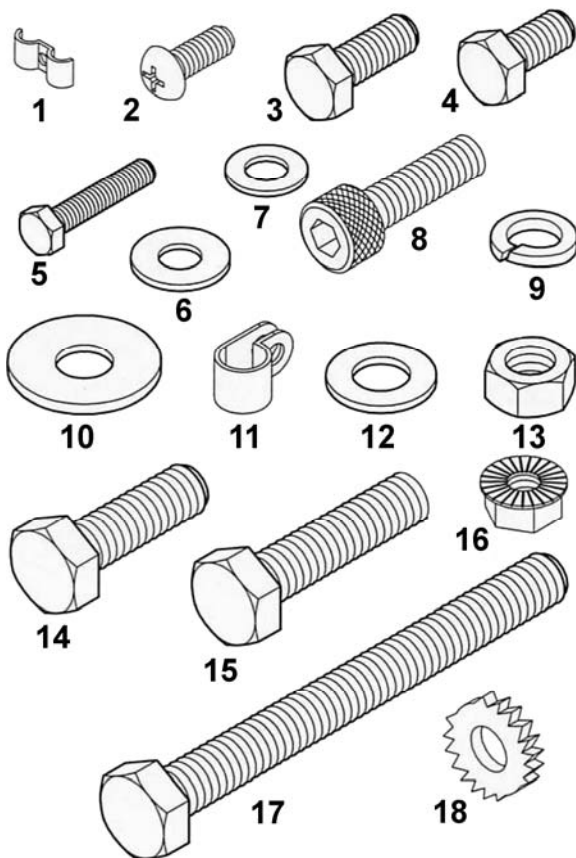

Hardware Bag for the Saw Body

## Hardware Bag for Saw Body

- 1 – Wire Clip (1)
- 2 – Pan Head Screw M5x12 (3)
- 3 – Hex Cap Screw M6x16 (1)
- 4 – Hex Cap Screw M6x10 (2)
- 5 – Hex Cap Screw M6x20 (2)
- 6 – Flat Washer M6x16 (2)
- 7 – Flat Washer M6x13 (2)
- 8 – Socket Head Cap Screw M8x25 (2)
- 9 – Spring Washer M8 (4)
- 10 – Flat Washer M8x30 (2)
- 11 – Cord Clamp (1)
- 12 – Flat Washer M8x18 (4)
- 13 – Hex Nut M8 (1)
- 14 – Hex Cap Screw M8x30 (2)
- 15 – Hex Cap Screw M8x35 (4)
- 16 – Serrated Hex Flange Nut M8 (4)
- 17 – Hex Cap Screw M8x80 (1)
- 18 – Gear Washer M5 (1)

## Hardware Bag for Stand Assembly

- 1 – Carriage Bolt M8x16 (40)
- 2 – Serrated Hex Flange Nut M8 (40)

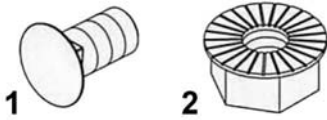

Hardware Bag for Stand Assembly

## Tools Required for Assembly

- 1 Accurate Straight Edge (approximately 2 ft)
- 1 Cross-point Screwdriver
- 1 6mm Hex Wrench
- 1 10mm Box Wrench
- 1 13mm Box Wrench

**Note:** Use of sockets and ratchets will speed assembly time but are not required.

## Assembly

**⚠WARNING** Read and understand all assembly instructions before attempting assembly! Failure to comply may cause serious injury!

The required hardware for all assembly on this machine is found in the *Hardware Bag for Stand Assembly and Hardware Bag for Saw Body*.

## Unpacking and Cleanup

1. Finish removing all contents from the shipping carton. Do not discard the carton or packing material until the bandsaw is assembled and is running satisfactorily.
2. Inspect the contents for shipping damage. Report damage, if any, to your distributor.
3. Compare the contents of the shipping carton with the contents list in this manual. Report shortages, if any, to your distributor.

## Stand

Referring to Figure 1.

1. Assemble the legs (A) to the table (B). Each leg requires 6 ea M8 x 16 carriage bolts (C) and 6 ea M8 flange nuts. Hand-tighten only at this time.
2. Assemble the long plates (E) to the legs (A). Each plate requires 4 ea M8 x 16 carriage bolts (F) and 4 ea M8 flange nuts (G). Hand-tighten only at this time.
3. Assemble the short plates (H) to the legs (A). Each plate requires 4 ea M8 x 16 carriage bolts (J) and 4 ea M8 flange nuts (K).
4. Slip the rubber feet onto the ends of the legs (L).
5. Ensure that the stand is on a level surface and all four legs are contacting the surface.
6. Tighten all flange nuts with a 13mm socket or wrench.

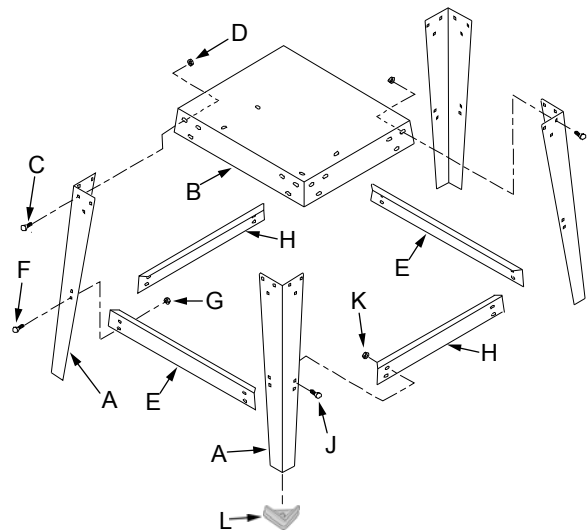

Figure 1



## Mounting Bandsaw to Table

**CAUTION** The saw body is heavy! Use caution when lifting! Stabilize until firmly attached to the stand! Failure to comply may cause serious injury!

Referring to Figure 2:

1. With the aid of a second person, lift the saw body (A) and place onto the stand top (B). Be sure front of saw (with JET logo) faces stand front (JET logo).
2. Place M8 flat washers (D) on M8x35 hex cap screws (C) and insert screws through four mounting holes in the bandsaw and stand.
3. Secure with four M8 flange nuts (E).

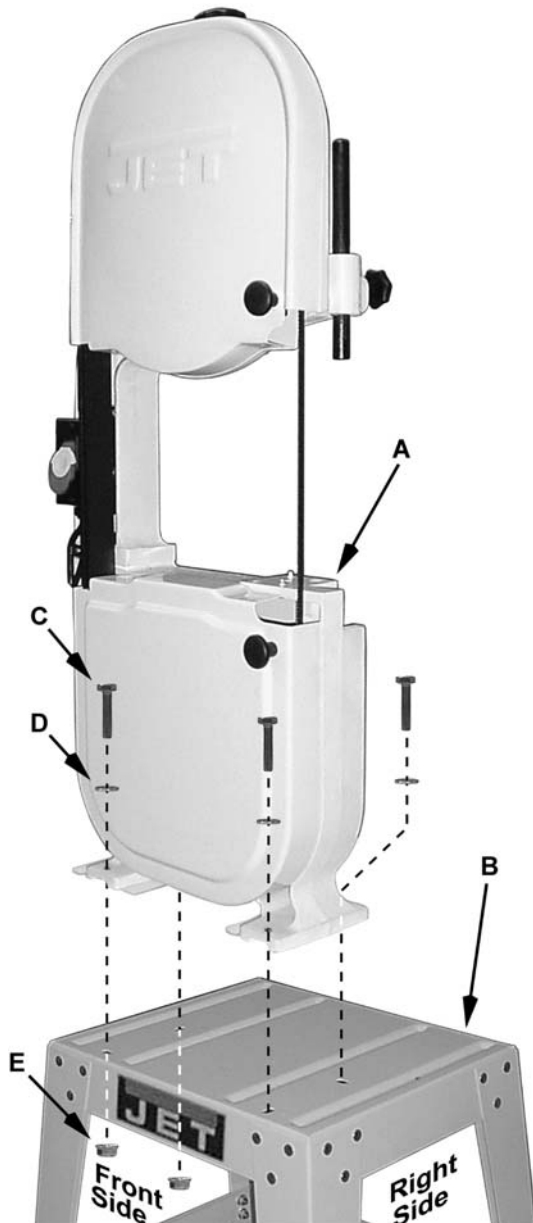

Figure 2

## Mounting the Motor

Referring to Figure 3:

1. From the right side of the saw, insert the end of the motor with the shaft and pulley (A) through the opening (B) in the casting.
2. Rest the motor on a section of 2x4 placed between the table and motor and against the casting of the saw body.
3. Align the two mounting holes on the motor with the slot and hole on the casting (C and D). The motor mounting holes should be visible from the inside of the saw body.

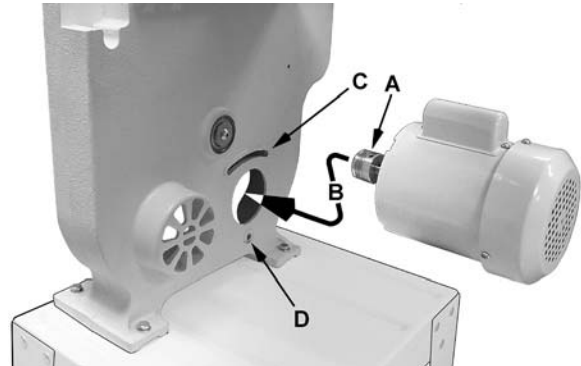

Figure 3

Referring to Figure 4:

4. With a 6mm hex wrench, secure the motor to the saw body with 2 each M8x25 socket head cap screws (A), M8 spring washers, and M8x30 flat washers (C). Do not tighten at this time.

**Note:** With the motor sitting on a section of 2x4 (refer to Step 2), the mounting holes can be easily aligned for screw insertion by lifting on the pulley (G).

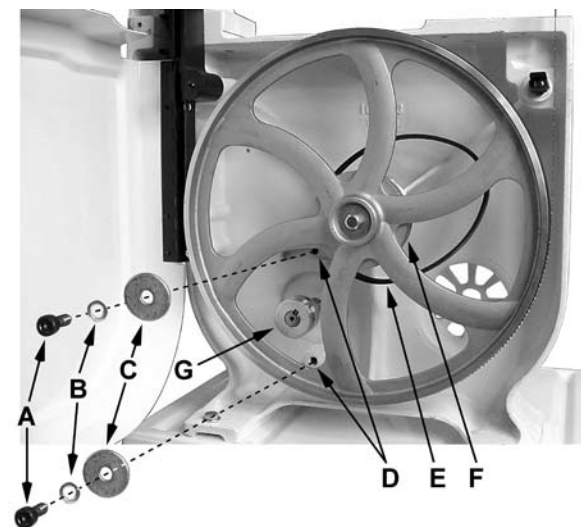

Figure 4

5. Standing on the *right side* of the band saw (Figure 2), pull the motor towards you.
6. Place the *belt* (C, Fig. 5) around the *wheel pulley* (B, Fig. 5) and *motor pulley* (A, Fig. 5).
7. Standing on the *right side* of the band saw, push the motor away to put tension on the belt.
8. With a 6mm hex wrench, tighten both *socket head cap screws* (D, Fig. 5).

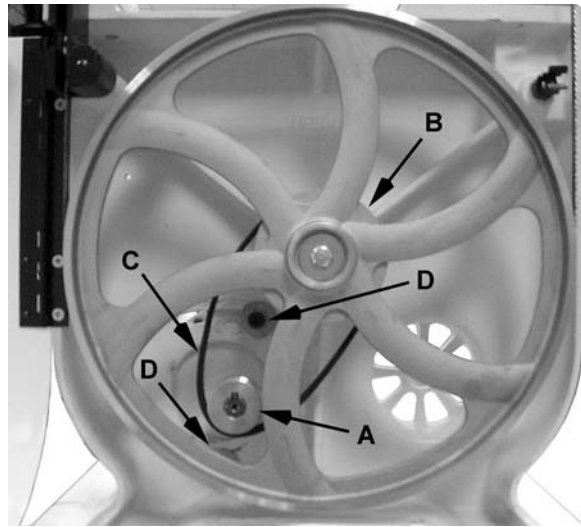

Figure 5

### Mounting the Switch

The switch is mounted to the saw body casting on the front side of the saw between the upper and lower doors.

Referring to Figure 6:

1. With a cross-point screwdriver, fasten the *switch* (A) to the *casting* (C) with the two screws already on the switch box (B). These screws also hold the *back plate* of the switch box in place.

**Note:** There are two mounting holes at the upper screw location. Use the left mounting hole.

2. In the remaining top mounting hole, secure with an M5x12 *pan head screw* (E) and M5 *gear washer*.
3. Secure the *electrical cords* (F) with a *wire clip* (G) and M5x12 *pan head screw* (H).

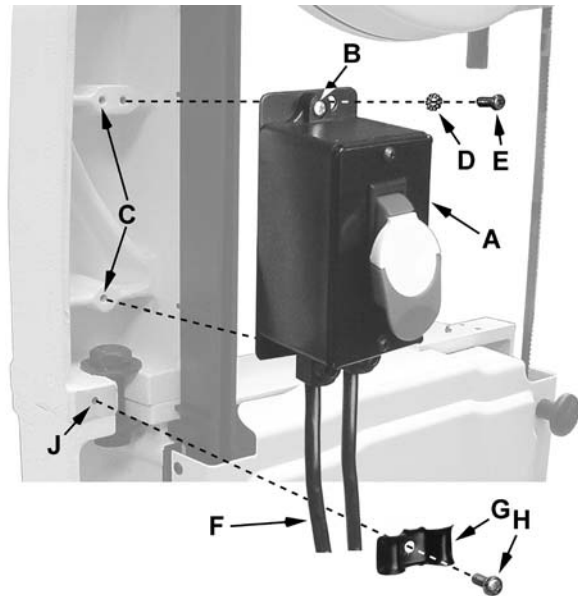

Figure 6

### Cord Clamp

Referring to Figure 7:

On the right side of the saw above the motor, secure the *electrical cord* (A) that connects the switch box to the motor with the *cord clamp* (B) and M5x12 *pan head screw* (C).

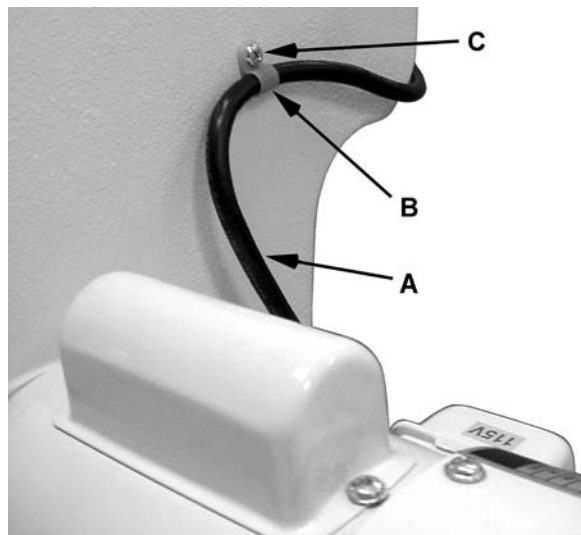

Figure 7

## Upper Blade Guard Assembly

Referring to Figure 8:

Secure the *upper wheel blade guard* (A) to the *upper support bracket post* (B) with two each M6x10 *hex cap screws* (C) and M6x16 *flat washers*.

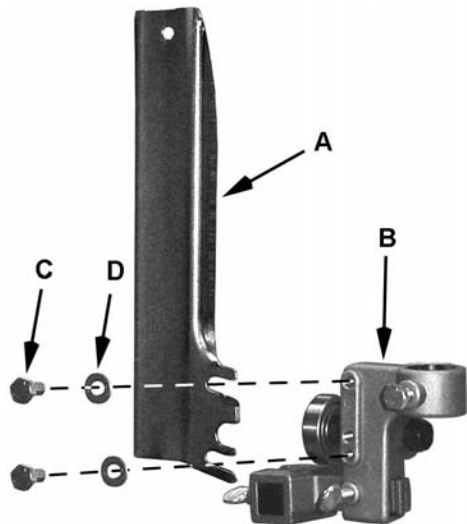

Figure 8

## Table Assembly

Referring to Figure 9:

1. Attach the lower wheel blade guard (D) and lower support bracket post (C) to the saw base (E), securing with two each M6x20

2. Attach the trunnion support bracket (G) to the saw base (E) with two M8x30 hex cap screws (J) and two M8 lock washers (K).
3. Thread the M8 hex nut (U) approximately half way onto the M8x80 hex cap screw (T). Then thread the screw half way into the trunnion support bracket (G). Adjustment will be made later.
4. Remove the table pin (M) and table insert (L) from the center opening.
5. Orient the table so that the saw blade will pass through the slot in the table and into the center opening. Continue holding up the table, and turn the table so the two screws that are hanging vertically from below the table (N) can slide into the holes on the trunnion support bracket (O). Lower the table. The screws should now protrude below the trunnion support bracket.
6. Attach lock knobs (H) to the ends of these screws.
7. Reinsert the table insert (L) and table pin (M).
8. Attach the upper blade guard assembly (Q) to the guide post (S).
9. Secure by tightening the hex cap screw (R). Loosen the lock knob (T) to raise or lower the guide post as needed.

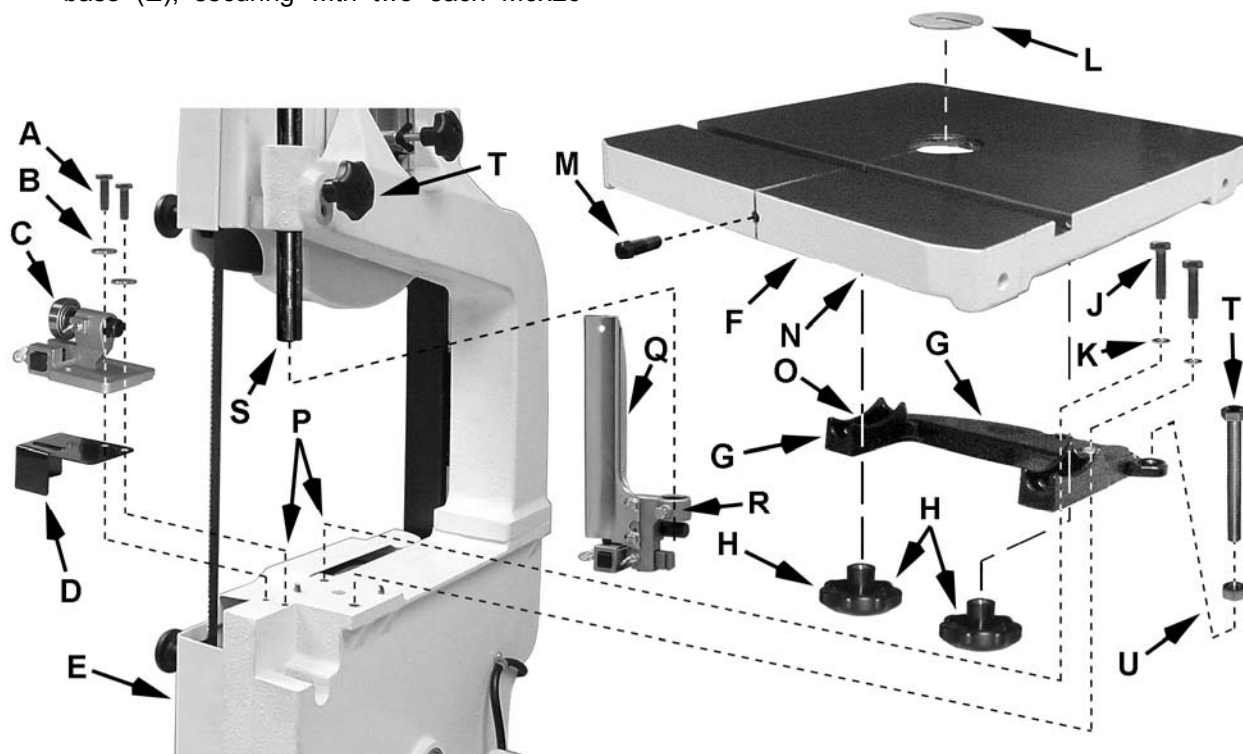

Figure 9

# Grounding Instructions

**⚠WARNING** This Band Saw must be grounded while in use to protect the operator from electric shock.

In the event of a malfunction or breakdown, grounding provides a path of least resistance for electric current to reduce the risk of electric shock. This tool is equipped with an electric cord having an equipment-grounding conductor and a grounding plug that looks similar to the plug in Figure 10. The plug must be inserted into a matching outlet that is properly installed and grounded in accordance with all local codes and ordinances.

Do not modify the plug provided. If it will not fit the outlet, have the proper outlet installed by a qualified electrician.

Improper connection of the equipment-grounding conductor can result in a risk of electric shock. The conductor, with insulation having an outer surface that is green with or without yellow stripes, is the equipment-grounding conductor. If repair or replacement of the electric cord or plug is necessary, do not connect the equipment-grounding conductor to a live terminal.

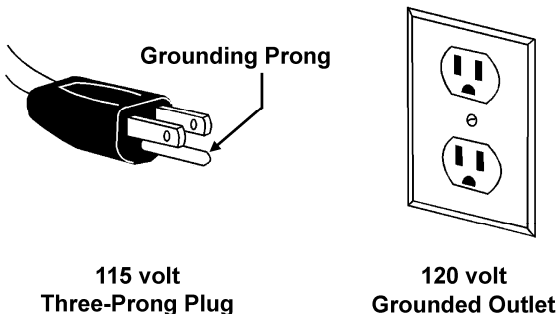

Figure 10

Check with a qualified electrician or service personnel if the grounding instructions are not completely understood, or if in doubt as to whether the tool is properly grounded.

Repair or replace a damaged or worn cord immediately.

## 115 Volt Operation

As received from the factory, your bandsaw is ready to run at 115-volt operation. This bandsaw, when wired for 115 volts, is intended for use on a circuit that has an outlet and a plug that looks like the one illustrated in Figure 10. A temporary adapter, like the adapter in Figure 11, may be used to connect this plug to a two-pole receptacle, as shown in Figure 11, if a properly

grounded outlet is not available. The temporary adapter should only be used until a properly grounded outlet can be installed by a qualified electrician. This adapter is not applicable in Canada. The green colored rigid ear, lug, or tab, extending from the adapter, must be connected to a permanent ground such as a properly grounded outlet box, as shown in Figure 11.

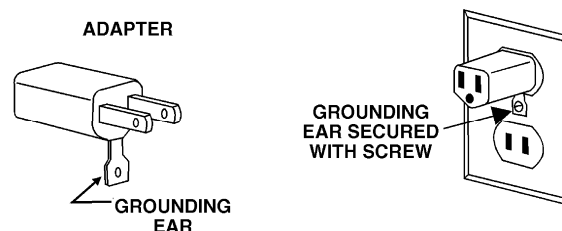

Figure 11

## 230 Volt Conversion

If 230V, single-phase operation is desired, the following instructions must be followed:

Disconnect machine from power source.

This band saw is supplied with four motor leads that are connected for 115V operation, as shown in Figure 12. Reconnect these four motor leads for 230V operation, as shown in Figure 12.

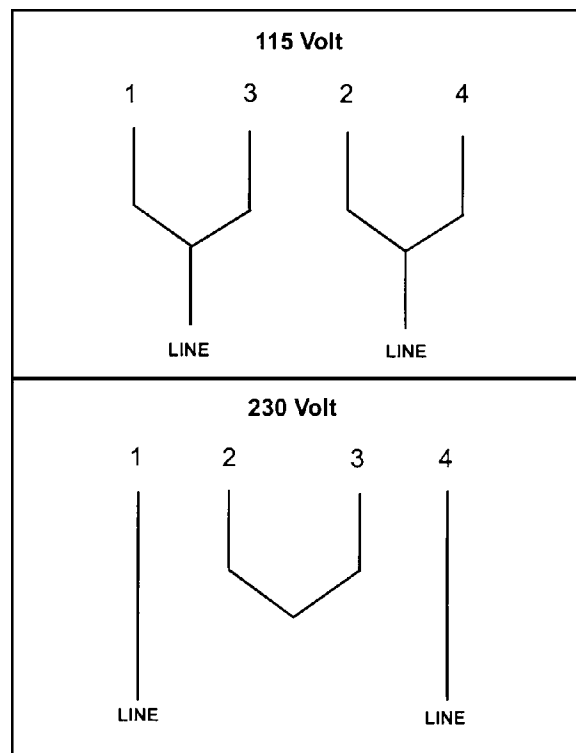

Figure 12

The 115V attachment plug supplied with the band saw must be replaced with a UL/CSA listed plug suitable for 230V operation, as shown in Figure 13. Contact your local authorized JET service center or qualified electrician for proper procedures to install the plug. The band saw must comply with all local and national codes after the 230-volt plug is installed.

The band saw with a 230-volt plug should only be connected to an outlet having the same configuration (Figure 13). No adapter is available or should be used with the 230-volt plug.

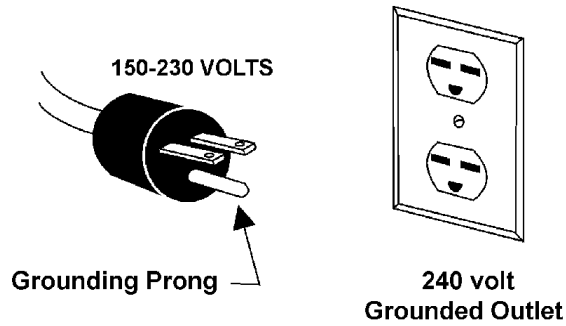

Figure 13

**IMPORTANT:** In all cases (115 or 230 volts), make certain the receptacle in question is properly grounded. If you are not sure, have a registered electrician check the receptacle.

It is recommended that the JWBS-14OS Band Saw be connected to a dedicated, minimum 15 amp circuit with a 15 amp circuit breaker or time delay fuse. **Local codes take precedence over recommendations.**

## Extension Cords

Use only three wire extension cords that have three-prong grounding plugs and three-pole receptacles that accept the tool's plug.

Make sure the cord is in good condition, and heavy enough to carry the current your band saw will draw. An undersized cord will cause a drop in line voltage, resulting in loss of power and overheating. Table 1 shows the correct size to use depending on cord length and the ampere rating on your machine's nameplate. If in doubt, use the next heavier gauge. The smaller the gauge number, the heavier the cord.

Repair or replace a damaged or worn cord immediately.

Power		Extension Cord	
Current (Amps)	Line voltage	Cord length in feet	Cord gauge (AWG)
0-6	120	0 to 25	18
		25 to 50	16
		50 to 100	16
		over 100	14
6-10	120	0 to 25	18
		25 to 50	16
		50 to 100	14
		over 100	12
10-12	120	0 to 25	16
		25 to 50	16
		50 to 100	14
		over 100	12
12-16	120	0 to 25	14
		25 to 50	12
		over 50	not recommended

Table 1

## Adjustments

**⚠WARNING** Unplug the machine from the power source before making any repairs or adjustments. Failure to comply may cause serious injury.

### Tilting the Table

1. Loosen the front and rear lock knobs (Figure 14).
2. Tilt table up to 45 degrees to the right or up to 10 degrees to the left. The angle can be read on the scale mounted to the trunnion.
3. Tighten two lock knobs (Figure 14).

**Note:** Table stop (Figure 14) must be adjusted downward to allow the table tilt to the left.

### Adjusting 90° Table Stop

1. Disconnect machine from power source.
2. Loosen lock knobs (Figure 14) and tilt table left until it rests against the table stop.
3. Use a square placed on the table and against the blade (Figure 15) to see if the table is 90 degrees to the blade.
4. If an adjustment is necessary, loosen lock knobs, tilt table to the right, and lock in place.
5. Loosen jam nut and turn table stop (Figure 14) left or right to raise or lower the stop. Tighten jam nut to hold table stop in place.
6. Unlock table, tilt back onto table rest and confirm table is 90 degrees with the blade.
7. If necessary, adjust scale pointer to zero.

### Changing Blades

**⚠WARNING** Blade teeth are sharp! Use care when handling the saw blade. Failure to comply may cause serious injury.

Referring to Figure 16:

1. Disconnect machine from power source.
2. Loosen blade tension by turning the tension knob counterclockwise (A).
3. Remove the table insert (B) and table pin (C).
4. Open both wheel covers (D, E).
5. Remove the blade from between upper (F) and lower blade guides (G). Remove blade from upper and lower wheels.
6. Turn the blade to direct it through the slot in table.

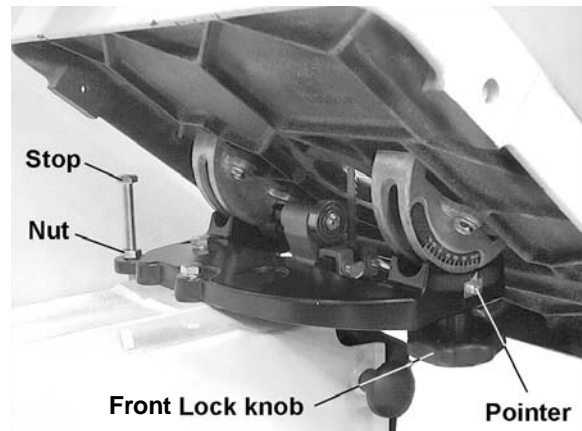

Figure 14

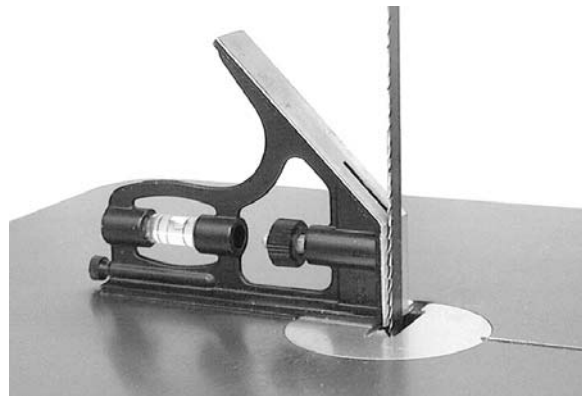

Figure 15

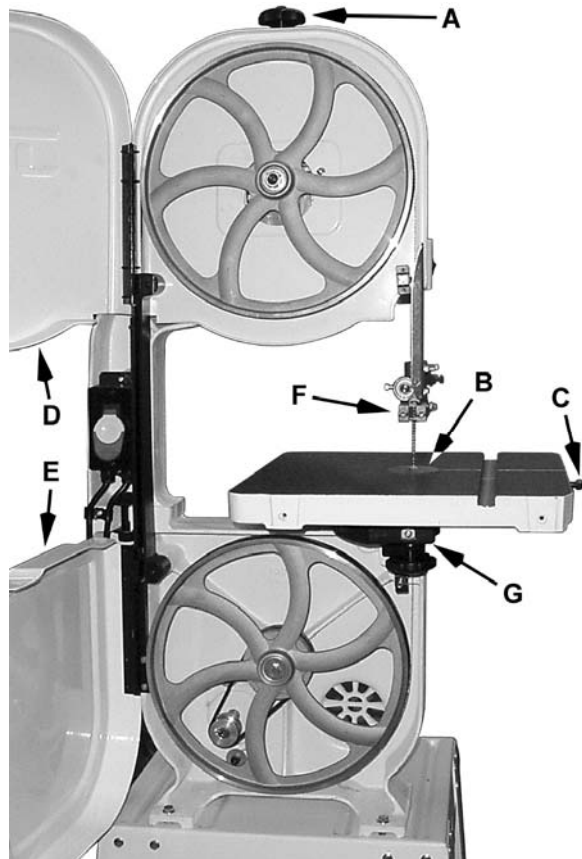

Figure 16

7. Guide new blade through table slot. Place blade in upper and lower blade guides.

**Note:** The blade teeth should face the operator, and they should point down toward the table.

8. Place blade in the middle of the upper and lower wheel.
9. Re-install table insert (B) and table pin (C).
10. Tension and track blade before operating saw. Find instructions for tensioning and tracking the blade in the *Adjusting Blade Tension* and *Adjusting Blade Tracking* sections.

## Adjusting Blade Tension

1. Disconnect machine from power source.
2. Turn blade tension knob (Figure 17) clockwise to tension blade.
3. Apply just enough tension to take the slack out of the blade.
4. Turn one wheel a few times to move the blade to the center of the tire
5. With a meter, tension the blade appropriately for the size of blade used.
6. A gauge (Figure 17) on the upper wheel slide bracket indicates the approximate tension according to the width of the blade. Initially, set the blade tension to correspond to the blade width as marked on the gauge.

**Note 1:** As you become more experienced with the saw, you may find it necessary to change the blade tension from the initial setting. Changes in blade width and the type of material being cut will have an effect on blade tension.

**Note 2:** Keep in mind that too little or too much blade tension can cause blade breakage.

## Adjusting Blade Tracking

**⚠ WARNING** Disconnect machine from the power source! Never adjust blade tracking with the machine running! Failure to comply may cause serious injury!

*Tracking* refers to how the blade is situated upon the wheels while in motion. The blade should track in the center of both wheels.

The blade must be properly tensioned before adjusting blade tracking. Make sure blade guides and blade bearings do not interfere with the blade.

1. Open the top wheel cover. Rotate the wheel forward by hand, and observe the position of the blade on the wheel. It should be in the center of the wheel.

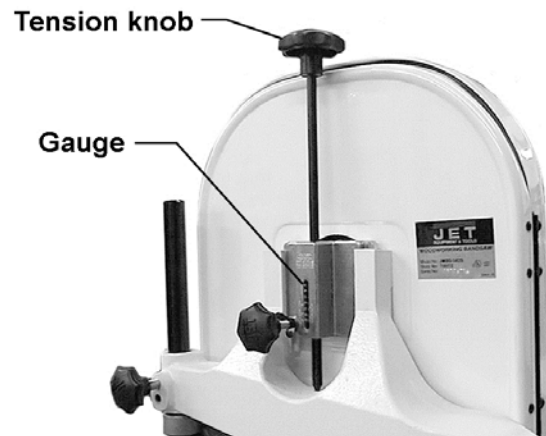

Figure 17

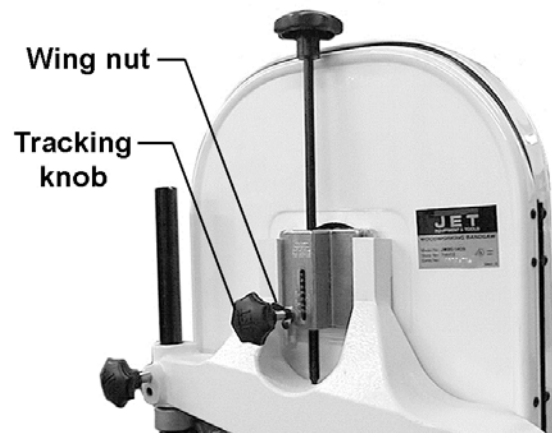

Figure 18

2. If adjustment is necessary, loosen wing nut (Figure 18). Tightening the tracking knob slightly will move blade so it tracks towards the rear of machine. Loosening the tracking knob slightly will cause the blade to track toward the front of the machine.
3. After blade is tracking in the center of the wheel, tighten the wing nut.

## Adjusting Upper Blade Guide Assembly

In Figure 19, the blade guard has been removed for clarity.

**⚠WARNING** Never operate the Band Saw without all guards in place and in working order.

Referring to Figure 19:

1. Disconnect machine from power source.
2. Loosen lock knob (A) and raise or lower the upper blade guide assembly (C) to just above the material being cut.
3. Tighten lock knob (A). Make sure blade guide blocks (D) are still flat to the blade. If adjustment is necessary, loosen *lock knob* (A) and rotate the assembly until the *guide blocks* (D) are flat to blade.

If movement of the *blade guide assembly* seems "stiff" when being raised or lowered, it can be adjusted to slide more easily. This is controlled by an internal spring and ball that provides varying degrees of resistance against the guide post.

To adjust tension on the spring:

4. Remove the *knob* (A).
5. Using a 5mm hex wrench, tighten or loosen the *setscrew* (B) until desired tension is reached.
6. Reattach and tighten the *knob* (A).

## Blade Guide Adjustment

**⚠WARNING** Never operate the Band Saw without all guards in place and in working order.

Referring to Figure 20:

1. Disconnect machine from power source.
  2. Remove the blade guard.
- Note:** Blade must already be tensioned and tracking properly.
3. Loosen *thumbscrews* (A) and move the *guide blocks* (B) as close to the *blade* (C) as possible without pinching it.
  4. Tighten *thumbscrews* (A).
  5. Loosen *thumbscrew* (D) and move the *guide block bracket* (E) in or out until the front edge of the *guide blocks* (F) are just behind the "gullets" of the saw teeth.
  6. Tighten thumbscrew (D).
  7. Replace the blade guard.

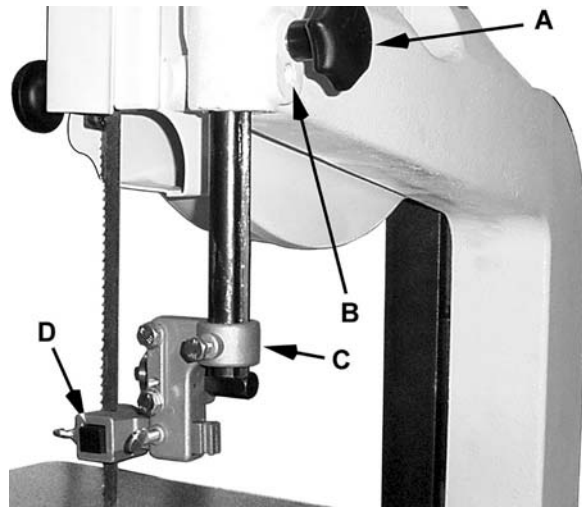

Figure 19

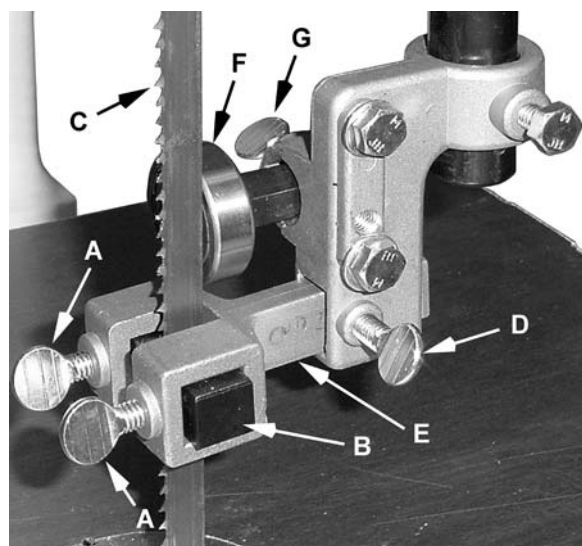

Figure 20

## Blade Support Bearing Adjustment

**⚠WARNING** Never operate the Band Saw without all guards in place and in working order.

1. Remove the blade guard.
2. Loosen the thumbscrew (G).
3. Adjust for a gap of 1/64" between the bearing (F) and blade (C).

**Note:** To set this distance quickly, you can place a dollar bill or piece of paper between support bearing and back of blade.)

4. Tighten the thumbscrew (G).
5. Replace the blade guard.

Repeat the *Blade Guide Adjustment* and *Blade Support Bearing Adjustment* for the *Lower Blade Guide Assembly*.



## Optional Accessories

- 708717A **JRB-14A Riser Block Kit**  
Increases depth of cut from 6" maximum to 12" maximum. Includes 6" cast block, long frame bolt, front and back blade guards, 105" blade, and mounting instructions with parts list.
- 708716 **JMG-14 Miter Gauge Assembly**  
For straight and angle cutting. Includes guide bar, pivoting support body, and adjustable stops.
- 708719 **JRB-14 Blade Block Set**  
Includes upper and lower replacement blocks made from a non-metallic composite material with a dry lubricant to reduce friction and heat.
- 5782171 **JRF-14 Deluxe Rip Fence with Resaw**  
Includes guide rails, rip fence assembly, resaw post, fasteners, and mounting instructions with parts list.
- 708127 **JRBG-14 Roller Bearing Guides**  
Provides three bearing contact points to maximize support and reduce friction. Kit contains upper and lower guide assemblies, mounting studs, adaptor blocks, and all mounting hardware.

## Troubleshooting JWBS-14OS Band Saw

Trouble	Probable Cause	Remedy
Saw stops or will not start.	Saw unplugged.	Check all plug connections.
	Fuse blown, or circuit breaker tripped.	Replace fuse, or reset circuit breaker.
	Cord damaged.	Replace cord.
Does not make accurate 45 or 90 degree cuts.	Table stop not adjusted correctly.	Check blade with square and adjust table stop.
	Angle pointer not set accurately.	Check blade with square and adjust pointer.
	Miter gauge out of adjustment.	Adjust miter gauge.
Blade wanders during cut.	Fence not aligned with blade.	Check and adjust fence (see fence manual).
	Warped wood.	Select another piece of wood.
	Excessive feed rate.	Reduce feed rate.
	Incorrect blade for cut.	Change blade to correct type.
	Blade tension not set properly.	Set blade tension according to blade size.
	Guides not set properly.	Adjust guides.
Saw makes unsatisfactory cuts.	Dull blade.	Replace blade.
	Blade mounted wrong.	Teeth should face operator and point downward.
	Gum or pitch on blade.	Remove blade and clean with oven cleaner or other solvent.
	Incorrect blade for cut.	Change blade to correct type.
	Gum or pitch on table.	Clean table.
Blade does not come up to speed.	Extension cord too light or too long.	Replace with adequate size and length cord.
	Low shop voltage.	Contact your local electric company.
Saw vibrates excessively.	Base on uneven floor.	Reposition on flat, level surface.
	Loose fasteners.	Tighten fasteners.

## Replacement Parts

Replacement parts are listed on the following pages. To order parts or reach our service department, call 1-800-274-6848, Monday through Friday (see our website for business hours, [www.jettools.com](http://www.jettools.com)). Having the Model Number and Serial Number of your machine available when you call will allow us to serve you quickly and accurately.

## Body Assembly (JWBS-14OS Band Saw)

Index No.	Part No.	Description	Size	Qty
1	JWBS14OS-101	Base		1
2	990180	Hex Cap Screw	M16x55	1
3	TS-155010	Flat Washer	M16	2
4	TS-154010	Hex Nut	M16	1
5	100031	Pin		4
6	JWBS14OS-106	Lower Wheel Shaft		1
7	BB-6204VV	Ball Bearing	6204LLU	2
8	KD050525	Key	5x5x25	2
9	TS-1550061	Flat Washer	M8	1
10	TS-2248162	Button Head Socket Screw	M8x16	1
11	JWBS14OS-111	Motor	3/4HP, 115/230V, 60Hz	1
	JWBS14OS-SC	Starting Capacitor (not shown)	200MFD, 125VAC	1
	JWBS14OS-CC	Capacitor Cover (not shown)		1
	JWBS14OS-CSS	Centrifugal Switch Set (not shown)		1
	JWBS14OS-MFC	Motor Fan Cover (not shown)		1
12	JWBS14OS-112	Motor Pulley		1
13	TS-1523031	Set Screw	M6x10	1
14	994534	Switch	Tumble Type	1
15	990811	Tapping Screw	M3.5x12	2
16	TS-1550021	Flat Washer	M4	2
17	JWBS14OS-117	Switch Plate		1
18	TS-1533052	Pan Head Screw	M5x16	2
19	WE050000	Star Washer	M5	2
20	523028	Switch Box		1
21	150056	Switch Backing Plate		1
23	990821	Pan Head Screw	M5x6	2
24	998654	Strain Relief		2
25	JWBS14OS-125	Power Cord		1
26	JWBS14OS-126	Motor Cord		1
27	998623	Strain Relief		1
28	JWBS14OS-128	Upper Frame Arm		1
29	990651	Lock Knob	M10x30	1
	100016ACP-1	Sliding Bracket Assembly (includes #30-39,125) <i>(serial no. 07112632 and higher)</i>		1
	100016ACP	Sliding Bracket Assembly <i>(serial no. 07112631 and lower)</i>		1
30	100016A-1	Sliding Bracket <i>(serial no. 07112632 and higher)</i>		1
31	NW080000	Wing Nut	M8	1
32	990652	Lock Knob	M8x45	1
33	990653	Blade Adjusting Screw		1
34	100021	Steel Pin		2
	A100019	Upper Wheel Shaft Hinge Assy (includes #35 thru 37)		1
35	150086	Upper Wheel Shaft		1
36	992314	Spring Pin	φ4x24	1
37	100019	Upper Wheel Shaft Hinge		1
38	100015A	Coil Spring		1
39	150090	Square Nut	M10	1
40	JWBS14OS-140	Upper Wheel		1
41	100025A	Wheel Protector		2
42	TS-1540083	Hex Nut	M12	1
43	992522	Retaining Ring	R35	2
44	BB-6202ZZ	Ball Bearing	6202ZZ	2
45	JWBS14OS-145	Lower Wheel		1
46	TS-1550061	Flat Washer	M8	1
47	JWBS14OS-147	Hex Head Bolt (Left Thread)	M8x20	1
48	JWBS14OS-148	Lower Wheel Guard		1
49	150024	Catch Knob	M8	2
50	WI080000	Gear Washer	M8	2

## Body Assembly (JWBS-14OS Band Saw)

Index No.	Part No.	Description	Size	Qty
51	PWBS14-136	Stud Latch		2
55	TS-1533042	Pan Head Screw	M5x12	2
56	150079	Catch		2
57	150054	Locating Bolt		2
58	990804	Tapping Screw	M4x8	12
59	150029W	Outer Wheel Cover		1
60		Saw Blade	6TPI 93-1/2"x3/8"	1
61	150028W	Inner Wheel Cover		1
62	JWBS14OS-162	Washer Head Screw	M5x8	2
63	150901	Upper Hinge		1
64	150066	Stud		2
65	110070	Blade Guard		1
66	150097	Washer		2
67	990811	Tapping Screw	M3.5x12	2
68	JWBS14OS-168	Poly V-Belt	185J05	1
69	150902	Lower Hinge		1
70	TS-1533032	Phillips Pan Head Machine Screw	M5x10	4
71	TS-1490061	Hex Cap Screw*	M8x35	4
72	TS-1550061	Flat Washer*	M8	4
73	TS-2361081	Lock Washer*	M8	4
74	JWBS14OS-174	Serrated Hex Flange Nut*	M8	4
75	523024	Wire Clip*		1
76	TS-1533042	Pan Head Screw*	M5x12	3
79	JWBS14OS-179	Upper Support Bracket Post		1
80	150013A	Thumb Screw	M6x16	1
81	150015A	Upper Spacing Sleeve		2
82	BB-6200ZZ	Ball Bearing	6200ZZ	2
83	JWBS14OS-183	Retaining Ring	S10	2
84	JWBS14OS-184	Guide Post		1
85	JWBS14OS-185	Support Bracket		1
86	708719	Guide Block		4
87	150013A	Thumb Screw	M6x16	1
88	150101	Lower Wheel Blade Guard		1
89	150014A	Thumb Screw	M6x12	5
90	100002A	Upper Wheel Blade Guard		1
91	TS-1550041	Flat Washer*	M6	2
92	TS-1482011	Hex Cap Screw *	M6x10	2
93	JWBS14OS-193	Lower Support Bracket Post		1
95	TS-1482041	Hex Cap Screw*	M6x20	2
96	TS-1550041	Flat Washer*	M6	2
97	JWBS14OS-197	Table	14"x14"	1
98	199037	Table Insert		1
99	992311	Spring Pin	φ 3x8	1
100	100038	Table Pin		1
101	100042	Trunnion		2
102	100051	Scale		1
103	100041	Trunnion Clamp Shoe		2
104	TS-1482021	Hex Cap Screw	M6x12	6
105	110045	Trunnion Support Bracket		1
106	TS-1490051	Hex Cap Screw*	M8x30	2
108	110049	Pointer		1
109	990821	Pan Head Screw	M5x6	1
110	990554	Lock Knob	M10	2
111	TS-1491081	Hex Cap Screw	M10x50	2
112	TS-1490151	Hex Cap Screw*	M8x80	1

## Body Assembly (JWBS-14OS Band Saw)

Index No.	Part No.	Description	Size	Qty
113	TS-1540061	Hex Nut*	M8	1
115	TS-1504051	Socket Head Cap Screw*	M8x25	2
117	TS-1550061	Flat Washer*	M8	2
118	994181	Steel Ball		1
119	150099	Spring		1
120	TS-1525011	Socket Set Screw	M10x10	1
121	JWBS14OS-1121	Spring Nut	M4	2
122	JWBS14OS-1122	Cord Clamp*		1
124	TS-1482031	Hex Cap Screw *	M6x16	1
125	100018	Indicator		1
127	WE050000	Gear Washer	M5	1
128	TS-1481011	Hex Cap Screw	M5x8	1
129	JWBS14OS-1129	Brush		1
	JWBS14OS-SBHK	Saw Body Hardware Kit		1

\* ..... included in Saw Body Hardware Kit, Part No. JWBS14OS-SBHK

# Body Assembly (JWBS-140S Band Saw)

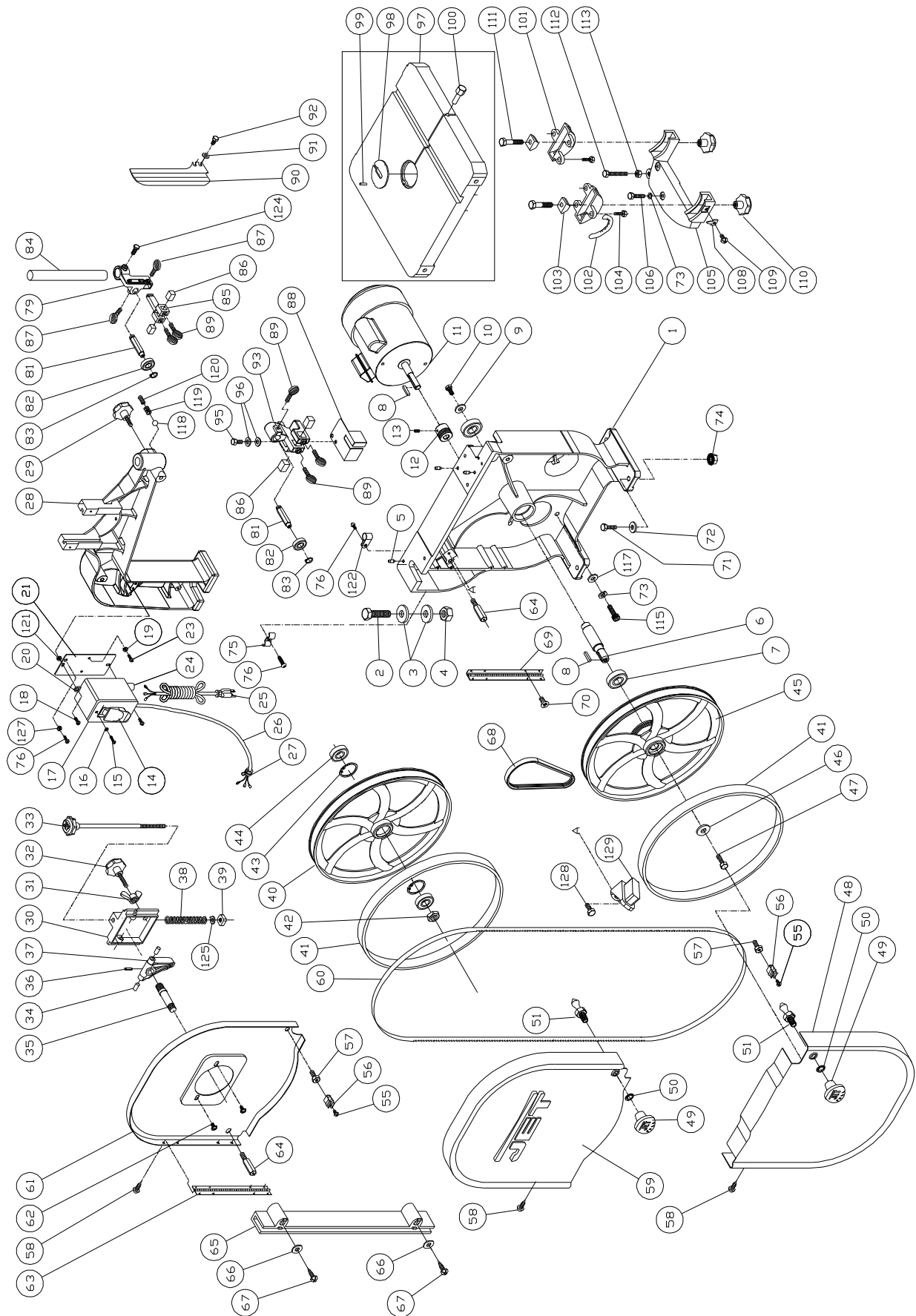

## Open Stand Assembly (JWBS-14OS Band Saw)

Index No.	Part No.	Description	Size	Qty
1	JWBS14OS-201	Stand Top		1
2	150603W	Stand Leg		4
3	612050W	Support Plate (long)		2
4	612051W	Support Plate (short)		2
5	JWBS14OS-205	JET Logo Label		1
6	991516	Carriage Bolt**	M8x16	40
7	JWBS14OS-174	Serrated Hex Flange Nut**	M8	40
8	JWBS14OS-208	Rubber Foot		4
	JWBS14OS-SAHK	Stand Assembly Hardware Kit		1

\*\* ..... included in Stand Assembly Hardware Kit Part No. JWBS14OS-SAHK

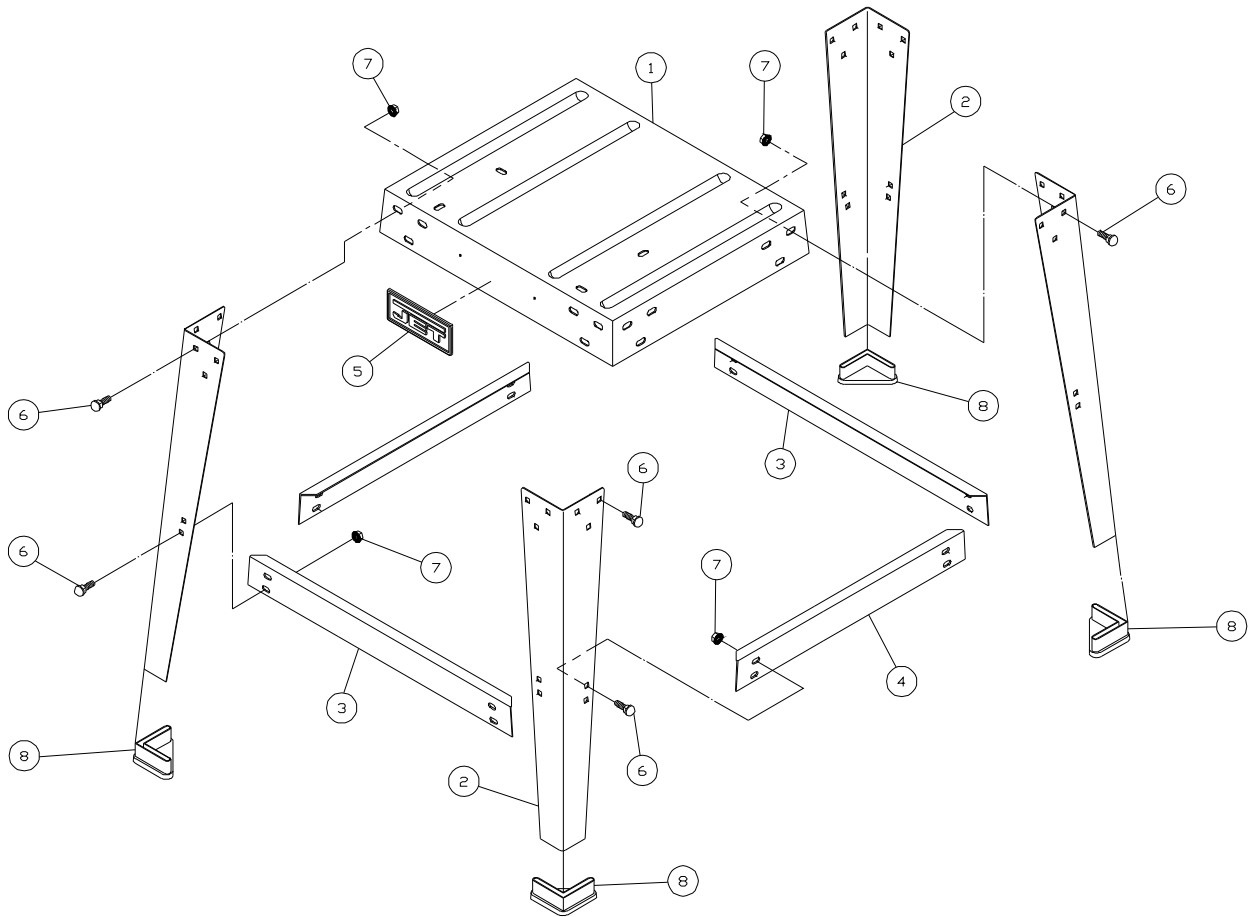

# Electrical Connections

## Electrical Schematic - 115V

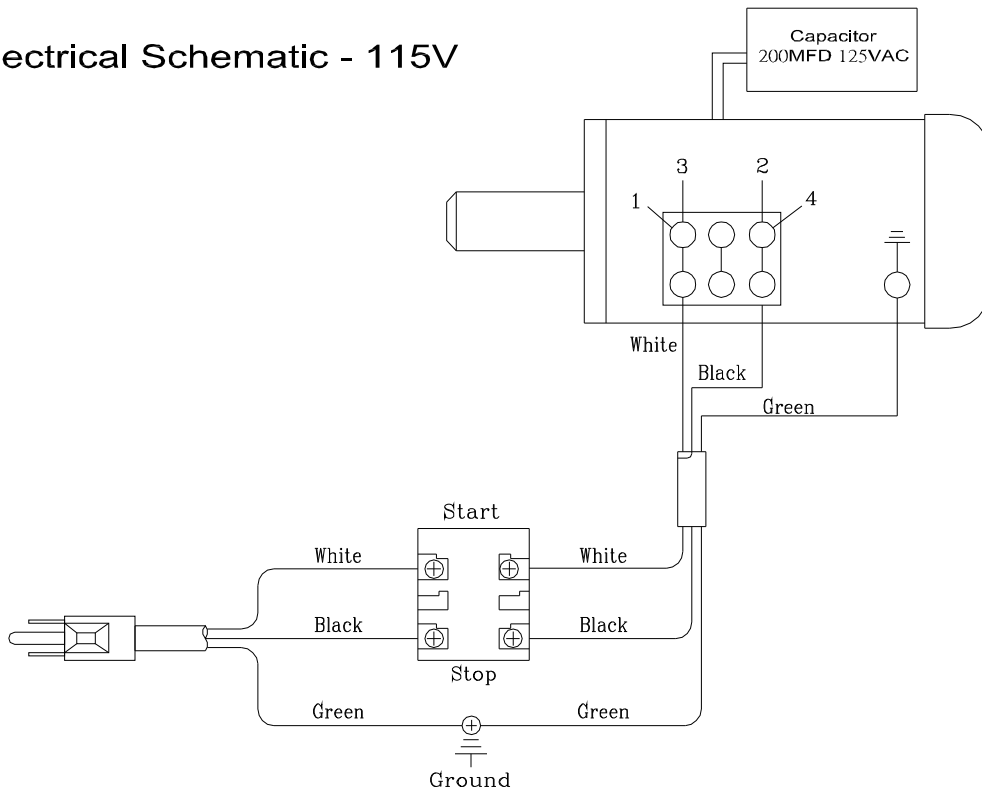

## Electrical Schematic - 230V

